



❖ Features

Small size,large capacitance
Long life,maintenance free
Wider operating temperature(-25℃~+70℃) than battery

❖ Application

Memory back-up power for Smart e-meter,Smart water meter,Video,Printer,Cameras,
Car stereo audio,Rice cooker,Electronic toy,Computer Camcorder etc.

❖ General Characteristics



Items	Criteria
Rated voltage(V)	5.5V
Rated discharge capacitance	0.1F
Capacitance tolerance	-20%~+80%
Max. work voltage	6.0V
ESR Max (Ω) AC@1KHz	50Ω
Work temperature range	-25℃~+70℃
Storage temperature range	-40℃~+85℃
Max. Stored energy (mWh)	0.42
Nominal current (A)	0.012
Max. Leakage current after 24hrs @RT (μA)	2.0
Low temperature (-25℃)	ΔC/C ≤50%, ESR ≤5 times specified value
Endurance	After 1000hrs application of rated voltage(DC) at 70℃, ΔC/C ≤30%, ESR ≤4 times specified value
Shelf life	After 1000hrs storage without load at 70℃, ΔC/C ≤30%, ESR ≤4 times specified value

❖ Product Dimensions

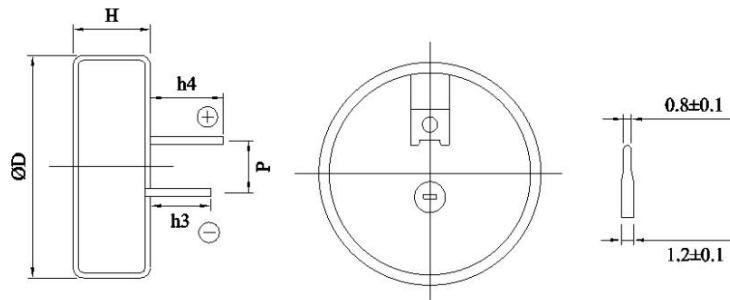

Type C

Size:

Items	Criteria	Items	Criteria
ΦD	13.5±1.0 mm	H	6.6±1.0 mm
P	5.0±1.0 mm	h3	5.5±1.0 mm
h4	6.5±1.0 mm	weight	3.0g

Packing:

Part Number	Quantity (pcs)		Dimension (LxWxH) mm		Total weight (kg)
	Inner	Outer	Inner	Outer	
GTSE-5R5-104ZC	561	2244	260x188x90	400x280x290	9.8

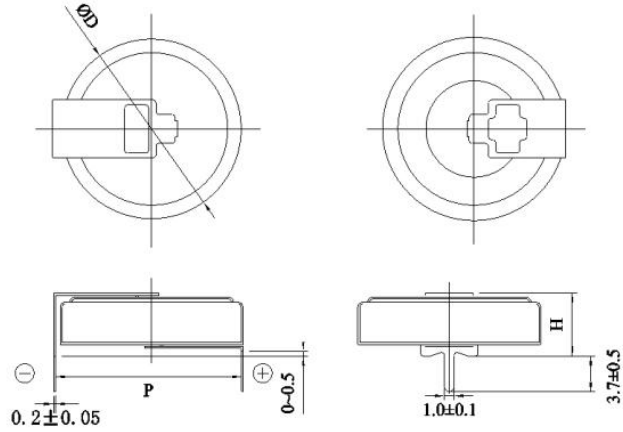

Type H

Size:

Items	Criteria	Items	Criteria
ΦD	11.5±1.0 mm	H	6.0±1.0 mm
P	10±0.5mm	weight	1.4g

Packing:

Part Number	Quantity (pcs)		Dimension (LxWxH) mm		Total weight (kg)
	Inner	Outer	Inner	Outer	
GTSE-5R5-104ZH	960	3840	260x188x70	400x280x170	8.9

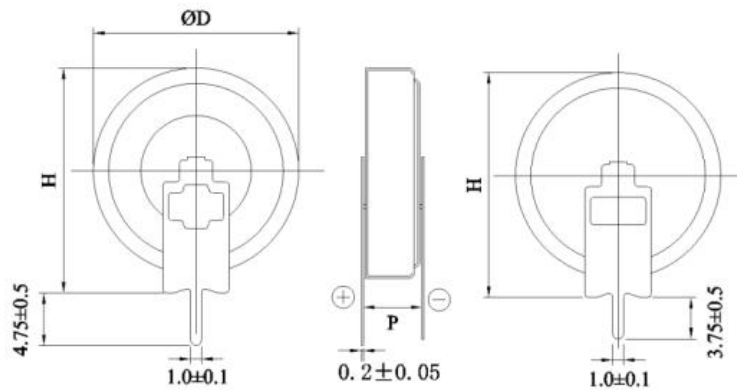

Type V

Size:

Items	Criteria	Items	Criteria
ΦD	11.5±1.0 mm	H	12.5±1.0 mm
P	5.0±0.5 mm	weight	1.4g

Packing:

Part Number	Quantity (pcs)		Dimension (LxWxH) mm		Total weight (kg)
	Inner	Outer	Inner	Outer	
GTSE-5R5-104ZV	2450	9800	260x188x70	400x280x170	16.7



❖ **Packing method**

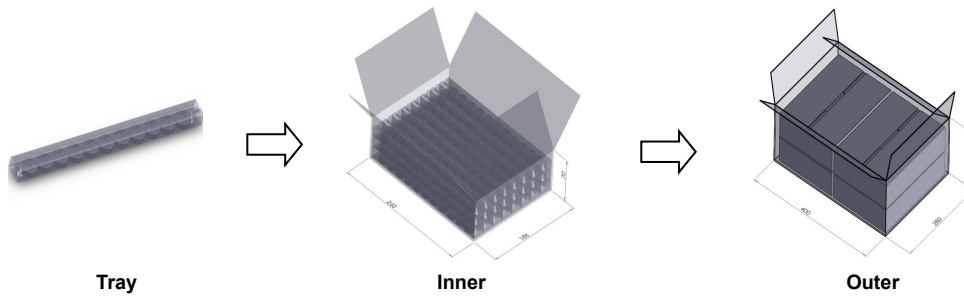

❖ **How to order**

Part number: **GTSE-5R5-104ZC/H/V 1000pcs**

The customer is requested to write down your information and contact GTCAP in advance, if and when the customer needs applications or operating conditions other than those described in this document. GTCAP could design and build such products according to your special request.

No.	Special Request	Criteria
1		
2		

Company Name: _____ E-mail: _____ Signature: _____ Date : _____

❖ **Handling Precautions and Guidelines**

For safety application, please contact GTCAP directly for any technical specifications, handling precautions and guidelines critical to application.

1 Precautions

- (1) Prohibition of disassembly
The disassembling may generate internal short circuit in the cell, which may cause gassing, leakage, explosion, or other problems. Electrolyte is harmful: In case the electrolyte come into contact with the skin, or eyes, physicians shall flush the electrolyte immediately with fresh water and medical advice is to be sought.
- (2) Prohibition of dumping of cells into fire
These may cause explosion of the cells, which is very dangerous and is prohibited.
- (3) Prohibition of cells immersion into liquid
The cells shall never be soaked with liquids such as water, seawater, drinks such as juices, coffee or others.
- (4) Prohibition of use of damaged cells
The cells might be damaged during shipping by shock. If any abnormal features of the cells are found such as damages in the cell package, smelling of an electrolyte, an electrolyte leakage and others, the cells shall never be used any more. The Cells with a smell of the electrolyte or a leakage shall be placed away from fire to avoid firing or explosion.

2 Application Guidelines

- (1) It is not suitable that cell is used under such conditions: AC circuit and wave filing.
- (2) Work voltage of cell should not exceed Max. work voltage of cell during using. Otherwise, will shorten shelf life, even cause swelling, leakage or crack.
- (3) Please check the polarity before using. If working under reverse polarity, cell will not only shorten shelf life, but also heavy damage, such as swelling, electrolyte leakage etc.
- (4) Environment
Work temperature will have an influence on shelf life of cell. As usual, higher work temperature will shorten shelf life. So, it is better that cell works under as possible as low environmental temperature.
Work temperature of cell should consider internal work temperature in the unit and temperature rise when cell works.
- (5) IR drop
When main power sources shut down, cell will change into work mode from failure mode, at the same time, OCV will decrease due to IR drop. So please choose proper product type according to impedance specified in product datasheet and applied current.
- (6) Cells in series connection
When cells in series connection for higher work voltage, it should be assured that work voltage of any single cell must not exceed Max. work voltage of single cell, otherwise, will shorten shelf life, even cause swelling, leakage or crack.
- (7) Soldering
Heat shock will decrease electric performance of cell, even cause swelling, leakage or crack.
Soldering temperature should not exceed 230°C, soldering time should not exceed 5s.
Please don't use reflow soldering of infrared heating and air heating.